

Revisions				Approvals		
Description	By	Approved	Date		By	Date
				County Engineer		
				Recommended by Deputy Co. Eng.		

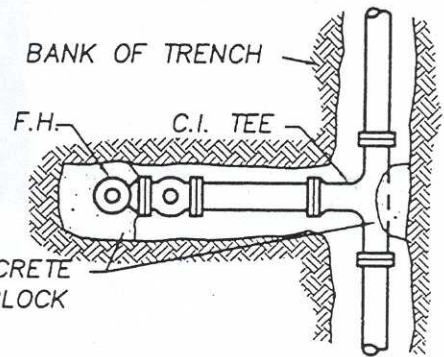
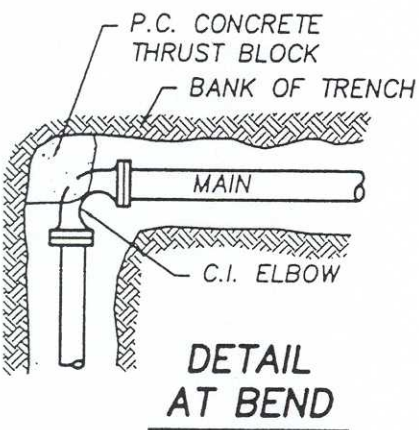
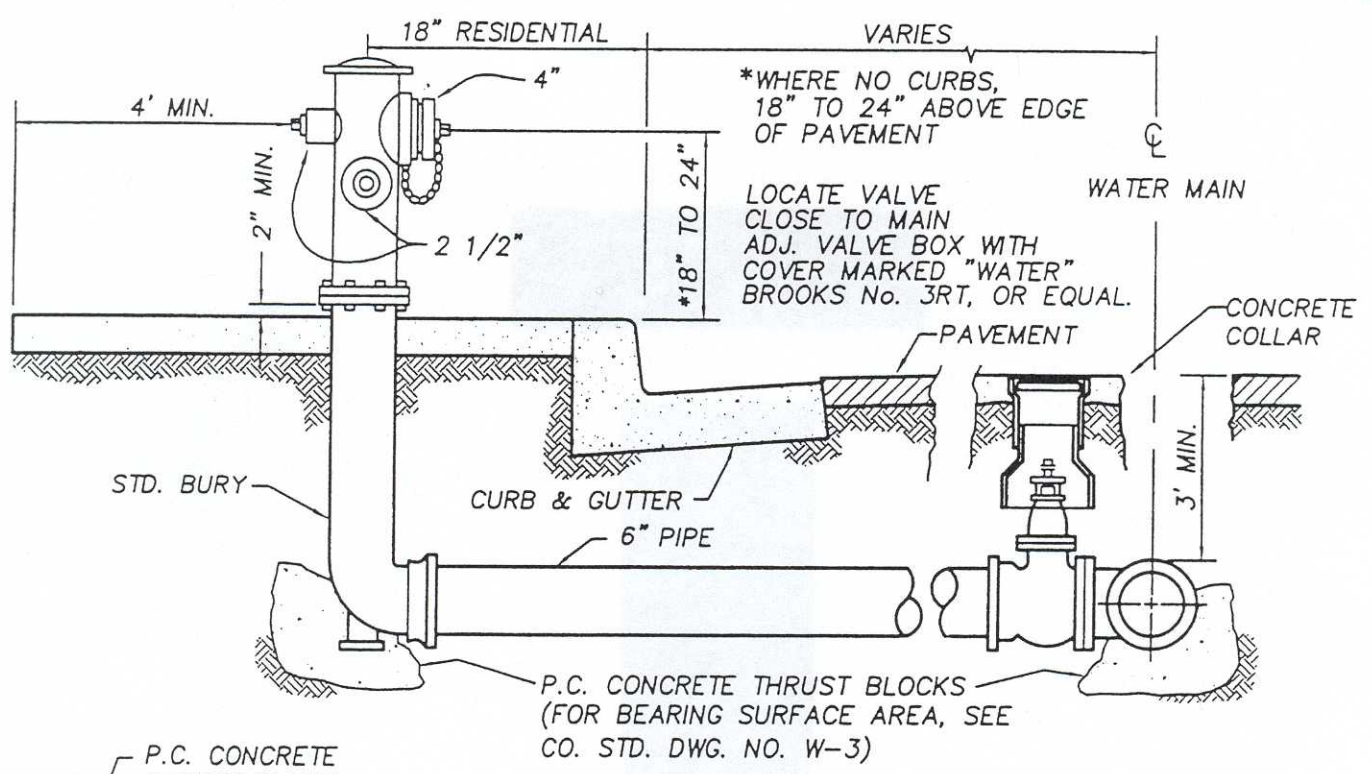

- NOTES:**
- THRUST BLOCKS SHALL BE CLASS "B" CONCRETE POURED ON UNDISTURBED SOIL.
 - EACH HYDRANT/FIRE VALVE SHALL BE IDENTIFIED BY A REFLECTORIZED BLUE RAISED PAVEMENT MARKER PER SECTION 10.301c OF THE UNIFORM FIRE CODE.
 - TYPE OF HYDRANT TO BE APPROVED BY THE COUNTY ENGINEER AND LOCAL FIRE AGENCY
 - A LESSER STANDARD FOR RURAL SUBDIVISIONS MAY BE APPROVED BY THE COUNTY ENGINEER.
 - EACH HYDRANT SHALL HAVE TWO 2½" OUTLETS AND ONE 4" SUCTION.

Specification Ref.	
Drawn: 5-91	By: PGH

COUNTY OF SAN LUIS OBISPO
 ENGINEERING DEPARTMENT
**FIRE HYDRANT
 INSTALLATION**

Scale:	NONE
Drawing No.	W-1

C:\PROGRAMS\ELICA\CAD2000\PROJECTS\CO.SI\DWG-1.DWG, Layout1, 02/04/00 01:04:59 PM, WISBELL